



2.3.11 Dye-Laser Cells



Dye-laser cells are used in a dye-laser to contain the dye in which the laser light is produced. Since it is located within the optical resonator, the cell must meet the highest optical specifications

Manufacture and Quality Control

Through the Hellma process of direct fusion, the cell windows are fused so accurately that their flatness can be guaranteed all the way to the edges. All cells in this series are furnished with the symbol DL after being tested in an interferometer. This symbol also serves to indicate the direction of the laser beam.

Not only macro cells but also micro and flow-through cells are available for the various types of dye-lasers.

The flow-through cells can also be produced with an integrated reflector for the excitation beam. The version shown here is of a cell body with the cross-section of a 90° prism. The pumping light enters through the hypotenuse. Depending on the application, cells can be made with varying channel diameter (minimum of 1 mm) and lengths.

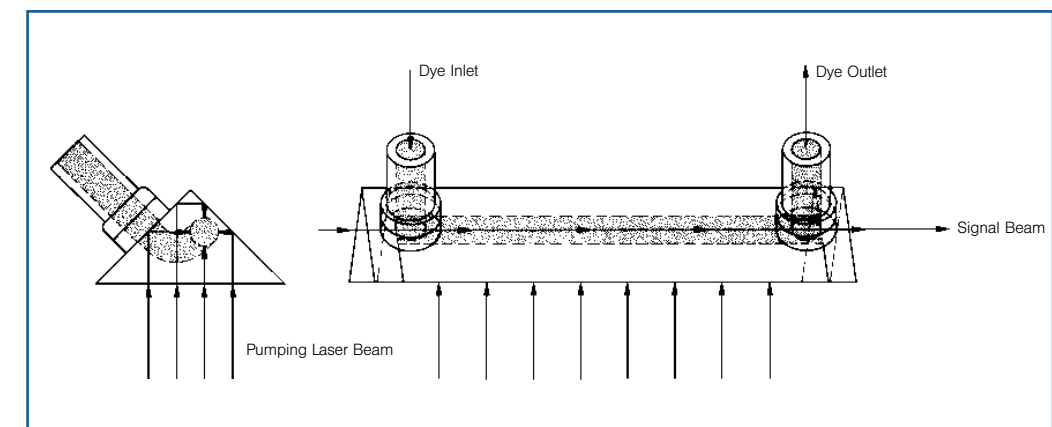

Dye Laser Cell with prismatic reflector



2.3.11 Dye-Laser Cells

2.3.11 Dye-Laser Cells both ends open

Catalogue Number	Window Material	Outside Dim. H x W x D mm	Inside Width mm	Volume μ l	Number of Windows	Remarks
101.070-QS	Quartz SUPRASIL	45 x 12.5 x 12.5	10 x 10	3500	4	with PTFE-lid on request with a polished base
101.171-QG*	Synthetic Quartz	40 x 26 x 26	20 x 20	12000	4	without lid
101.172-QG*	Synthetic Quartz	40 x 26 x 46	20 x 40	24000	4	without lid

*QG is a synthetic quartz with a transmission over 80 % for an empty cell between 200 nm and 2500 nm.

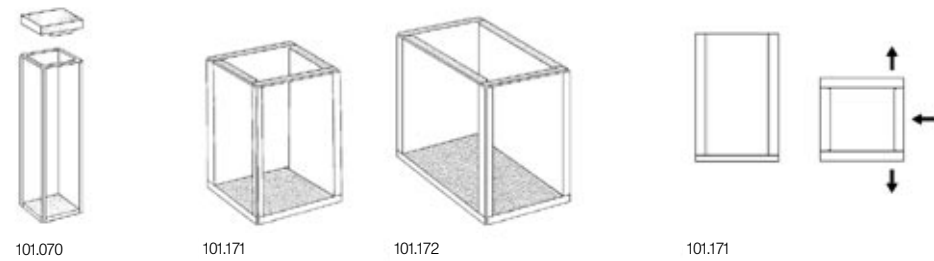

Catalogue Number	Window Material	Outside Dim. H x W x D mm	Inside Width mm	Volume μ l	Number of Windows	Remarks
690.071-QS	Quartz SUPRASIL	16 x 17.5 x 10	13.5 x 6	1300	4	
690.072-QS	Quartz SUPRASIL	25 x 12.5 x 20	10 x 1	100	4	
690.074-QS	Quartz SUPRASIL	40 x 12.5 x 12.5	10 x 10	4000	4	



with stoppers

Catalogue Number	Window Material	Outside Dim. H x W x D mm	Inside Width mm	Volume μ l	Number of Windows	Remarks
111.070-QS	Quartz SUPRASIL	46 x 12.5 x 12.5	10 x 10	3500	4	on request with a polished base
115.070-QS	Quartz SUPRASIL	40 x 12.5 x 12.5	10 x 2	400	4	on request with a polished base
115.071-QS	Quartz SUPRASIL	40 x 12.5 x 12.5	10 x 1	200	4	on request with a polished base
115.072-QS	Quartz SUPRASIL	40 x 12.5 x 12.5	10 x 0.5	100	4	on request with a polished base

